

Small size photoelectric sensors PSM series



Features

- 18mm threaded cylindrical mounting, easy to install
- Short case for small installation space
- Big knob design for easy adjustment
- IP67 protection, suitable for harsh environments
- With 360° visible bright LED status indicator
- Applicable to detect bright and partial transparent objects



Model

NPN NO/NC	PSM-PM3DNBR-E2	PNP NO/NC	PSM-PM3DPBR-E2
-----------	----------------	-----------	----------------

Specifications

Detection type	Polarized reflection	Indicator	Green LED: power, stable
Detection distance	3m*		Yellow LED: output, short circuit or overload
Light source	Red light (640nm)	Anti-ambient light	Anti-sunlight interference ≤ 10,000lux
Spot size	45*45mm@100cm		Incandescent light interference ≤ 3,000lux
Output	NPN NO/NC or PNP NO/NC	Operating temperature	-25...55 °C
Response time	≤0.5ms	Storage temperature	-35...70 °C
Supply voltage	10...30V DC	Protection degree	IP67
Consumption current	≤20mA	Certification	CE
Load current	≤200mA	Material	Housing: Nickel copper alloy; Filter: PMMA
Voltage drop	≤1V	Connection	M12 4-core connector
Distance adjustment	Single-turn potentiometer	Annex	M18 nut (2PCS), instruction manual, ReflectorTD-09
Circuit protection	Short-circuit, overload, reverse polarity protection		
NO/NC adjustment	Feet 2 is connected to the positive pole or hang up, NO mode; Feet 2 is connected to the negative pole, NC mode		

*This data is the result of the TD-09 test of the reflector of the Lanbao PSM polarized sensor.

Dimensions

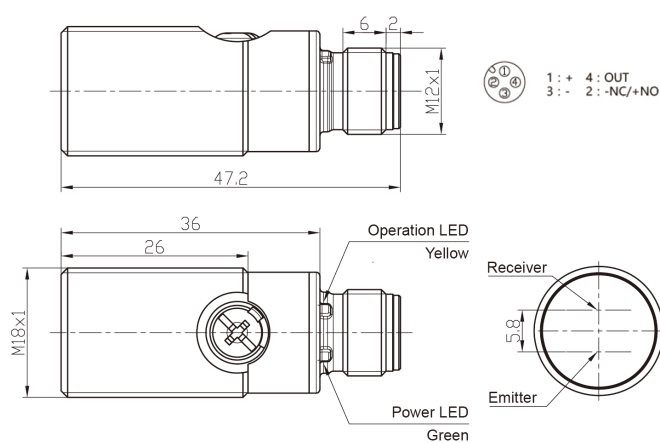

Circuit Diagrams

