

Small size photoelectric sensors PSM series



Features

- 18mm threaded cylindrical mounting, easy to install
- Short case for small installation space
- IP67 protection, suitable for harsh environments
- With 360° visible bright LED status indicator;
- Background suppression type, stable detection for both white and black targets;



Model

NPN NO/NC	PSM-YC10DNBR-E2	PNP NO/NC	PSM-YC10DPBR-E2
-----------	-----------------	-----------	-----------------

Specifications

Detection type	Background suppression	Indicator	Green LED: power, stable
Detection distance	10cm (unadjustable)		Yellow LED: output, short circuit or overload
Light source	Red light (660nm)	Anti-ambient light	Anti-sunlight interference ≤ 10,000lux;
Spot size	8*8mm@10cm		Incandescent light interference ≤ 3,000lux
Output	NPN NO/NC or PNP NO/NC	Operating temperature	-20...55 °C
Hysteresis	≤5%	Storage temperature	-35...70 °C
Response time	≤0.5 ms	Protection degree	IP67
Supply voltage	10...30 VDC	Certification	CE
Consumption current	≤20mA	Material	Housing: Nickel copper alloy; Filter: PMMA
Load current	≤100mA	Connection	M12 4-core connector
Voltage drop	≤1.8V	Annex	M18 nut (2PCS), instruction manual
Circuit protection	Short-circuit, overload, reverse polarity protection		
NO/NC adjustment	Feet 2 is connected to the positive pole or hang up, NO mode; Feet 2 is connected to the negative pole, NC mode		

Remarks: ①Detection object is 90% white card with size 20cm * 20cm;

②The green LED becomes weaker, which means that the signal is weaker and the sensor is unstable; The yellow LED flashes, which means that the sensor is shorted or overloaded;

Dimensions

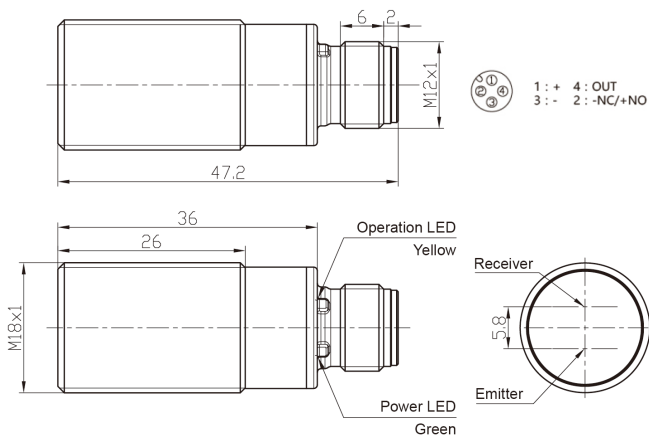

Circuit Diagrams

