



Photoelectric Sensor
V3,V4 SERIES
 •V4T/V3T-7000□□ DC Type
 •V4R/V3R-1200□□
 •V4D/V3D-200□□

INSTRUCTION MANUAL

- Confirm if the item meets your needs.
- Before the use, you should first thoroughly read this manual and operate correctly as mentioned.
- You should keep this manual at hand for proper use.

SPECIFICATIONS

Item	Type	Through Beam			AC/DC type			Diffused Reflection		
		Terminal Chamber	Cable	M12 Connector	Terminal Chamber	Cable	M12 Connector	Terminal Chamber	Cable	M12 Connector
Supply Voltage		V4T-7000N.P	V3T-7000N.P	V3T-7000CN.CP	V4R-1200N.P	V3R-1200N.P	V3R-1200CN.CP	V4D-200N.P	V3D-200N.P	V3D-200CN.CP
Current Consumption		DC10~30V Including ripple (P-P) 10%								
Light Source		35mA max.								
Detecting Distance		70m			12m / Reflector V-61			2m		
Hysteresis								20% max		
Sensitivity Adjustment		One turn volume								
Response Time		0.5ms max.								
Indicator		Output indicator (orange LED) / Stable indicator (green LED)								
Operating Mode		Light ON/Dark ON selectable by Volume								
Control Output		NPN/PNP open collector DC30V, 100mA max. (Residual voltage 1.8V max.)								
Environmental Illuminance	Sun Light	10,000lx								
	Incandescent Light	3,000lx								
Ambient Temperature		-25~55°C								
Ambient Humidity		35~85%/RH								
Storage Temp./Humidity		-40~70°C/35~95% RH								
Insulation Resistance		Min 20MΩ / DC500V								
Vibration Resistance		10~55Hz amplitude 1.5mm X, Y, Z each 2h								
Shock Resistance		500m/s ² X, Y, Z each 3times								
Protection Category		IEC 144 IP67								

OTHER PRECAUTIONS

- Be careful not to install the sensor at the following locations, as it may otherwise malfunction.
 - Where a lot of dust, vapor, or the like is present.
 - Where corrosive gas is produced.
 - Where water, oil or the like files directly onto the sensor.
 - Where strong vibration or shock is caused to the sensor.
- Do not use organic solvent, such as thinner, to remove contaminants from the body case, lid, and lens which are all of plastics. Using a dry rag, just wipe clean.
- When a switching regulator is to be used with a power supply, be sure to ground the Frame Ground Terminal.
- Do not use the sensor in a transient state at power on. (about 100ms)
- Do not run sensor cable near a high-voltage lines, or power lines or put them together in the same raceway. This warning should be strictly observed to prevent malfunctions caused by inductive interference.

⚠ Must not use this item as safety equipment for the purpose of human body protection.

HOW TO USE

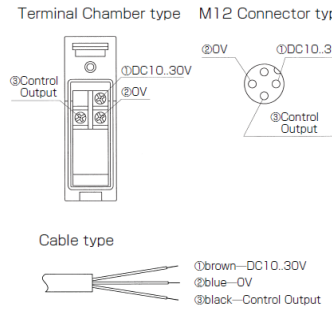

Connection

- Install the cables to match the connection terminal No. as shown below.
- Use either lead-in opening A or B according to the installation method involved.
- Install a cover (bolt) the lead-in opening not to be used.
- The figure below shows how the cables are installed when lead-in opening A is used.
- ※ 1 Cable packing is selected separately either for cable cover (bolt) according to cable diameter.
 Large φ4~φ6 Small φ6~φ8

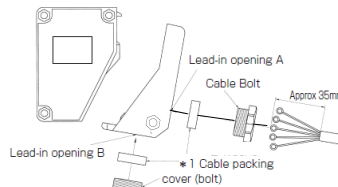

○ Dimensions of applicable solderless terminals

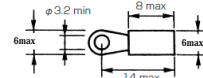

- Use solderless terminals with insulating tube.
- Use 4 to 8 mm diameter cables circular in section to maintain watertightness.
- Wrong wiring may be a cause of burned or damaged sensor. Pay due attention to wiring.
- Be careful not to install the cable near power lines, for otherwise the sensor may malfunction.
- Using the mounting accessories supplied, the sensor can be installed on either floor or wall.

INPUT AND OUTPUT CIRCUIT DIAGRAMS

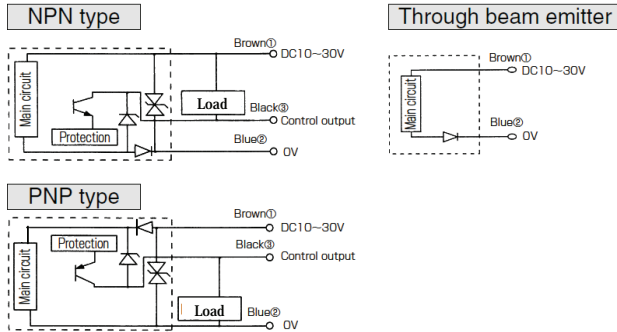

DIMENSIONS (Unit: mm)

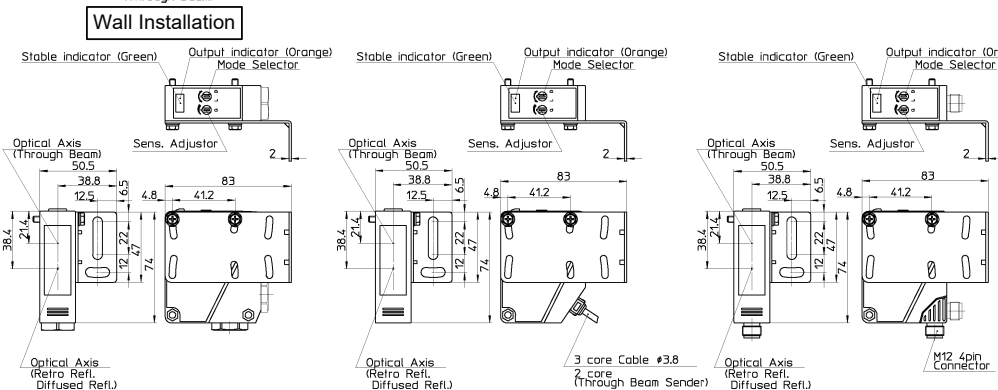
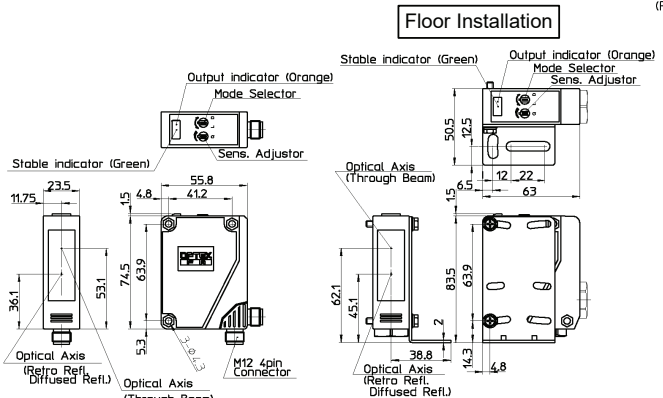
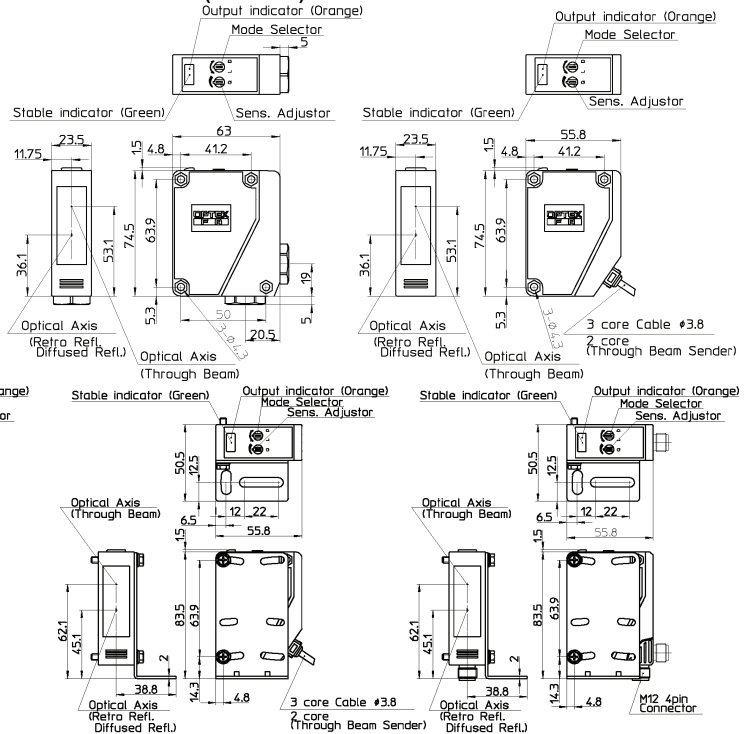

- Specifications and equipment are subject to change without any obligations on the part of manufacture.
- For more information, questions and comments regarding products, please contact us below.

Manufactured and sold by :





Photoelectric Sensor

V3, V4 SERIES

AC/DC Type

- V4T/V3T-7000
- V4R/V3R-1200
- V4D/V3D-200

INSTRUCTION MANUAL

- Confirm if the item meets your needs.
- Before the use, you should first thoroughly read this manual and operate correctly as mentioned.
- You should keep this manual at hand for proper use.

SPECIFICATIONS

Item	AC/DC type					
	Through Beam		Retro Reflection		Diffused Reflection	
Connection	Terminal Chamber	Cable	Terminal Chamber	Cable	Terminal Chamber	Cable
Supply Voltage	V4T-7000	V3T-7000	V4R-1200	V3R-1200	V4D-200	V3D-200
Current Consumption	DC24~240V ±10% AC24~240V±10% 50/60Hz					
Light Source	2VA max.(Class A),4VA max.(Class B)					
Detecting Distance	Red LED (635nm)					
Hysteresis	70m		12m / Reflector V-61		2m	
Sensitivity Adjustment	20% max					
Response Time	One turn volume					
Indicator	20ms					
Operating Mode	Output indicator (orange LED) / Stable indicator (green LED)					
Control Output	Light ON					
Relay Lifetime	Relay Output 1Form C AC240V / DC30V,3A max (Resistive)					
Environmental	Mechanical : 5X10 ⁷ / Electrical : 10 ⁷					
Illuminance	Sun Light 10,000lx					
Ambient Temperature	Incandescent Light 3,000lx					
Ambient Humidity	-25~55°C					
Storage Temp./Humidity	35~85%/RH					
Insulation Resistance	-40~70°C/35~95% RH					
Withstand Voltage	Min.20M Ω / DC500V					
Vibration Resistance	AC2,700V 50/60Hz 1minute					
Shock Resistance	10~55Hz amplitude1.5mm X, Y, Z each 2h					
Protection Category	500m/s ² X, Y, Z each 3times					
	IEC 144 IP67					

OTHER PRECAUTIONS

- Be careful not to install the sensor at the following locations, as it may otherwise malfunction.
 - Where a lot of dust, vapor, or the like is present.
 - Where corrosive gas is produced.
 - Where water, oil or the like files directly onto the sensor.
 - Where strong vibration or shock is caused to the sensor.
- Do not use organic solvent, such as thinner, to remove contaminants from the body case, lid, and lens which are all of plastics. Using a dry rag, just wipe clean.
- When a switching regulator is to be used with a power supply, be sure to ground the Frame Ground Terminal.
- Do not use the sensor in a transient state at power on. (about 100ms)
- Do not run sensor cable near a high-voltage lines, or power lines or put them together in the same raceway. This warning should be strictly observed to prevent malfunctions caused by inductive interference.

Must not use this item as safety equipment for the purpose of human body protection.

HOW TO USE

AC/DC model Terminal Chamber type

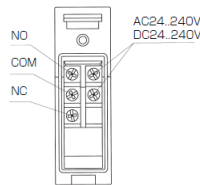

AC/DC model Cable type



Connection

- Install the cables to match the connection terminal No. as shown below.
- Use either lead-in opening A or B according to the installation method involved.
- Install a cover (bolt) at the lead-in opening not to be used.
- The figure below shows how the cables are installed when lead-in opening A is used.
 - ※1 Cable packing is selected separately either for cable or cover (bolt) according to cable diameter.
 - Large φ1~φ6 Small: φ6~φ8

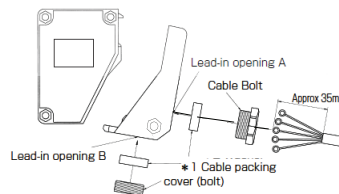

Dimensions of applicable solderless terminals

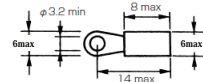

- Use solderless terminals with insulating tube.
- Use 4 to 8 mm diameter cables circular in section to maintain watertightness.
- Wrong wiring may be a cause of burned or damaged sensor. Pay due attention to wiring.
- Be careful not to install the cable near power lines, for otherwise the sensor may malfunction.
- Using the mounting accessories supplied, the sensor can be installed on either floor or wall.

INPUT AND OUTPUT CIRCUIT DIAGRAMS

AC/DC type

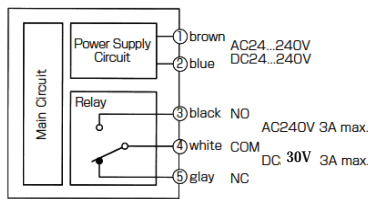

DIMENSIONS (Unit: mm)

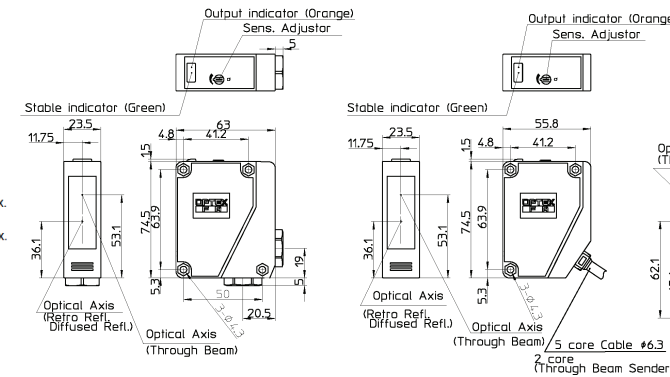

Floor Installation

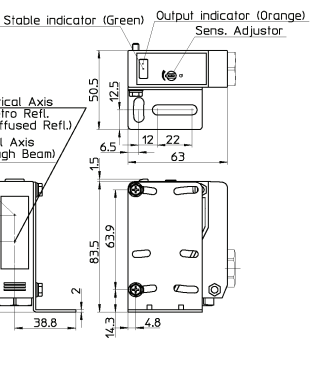

Wall Installation

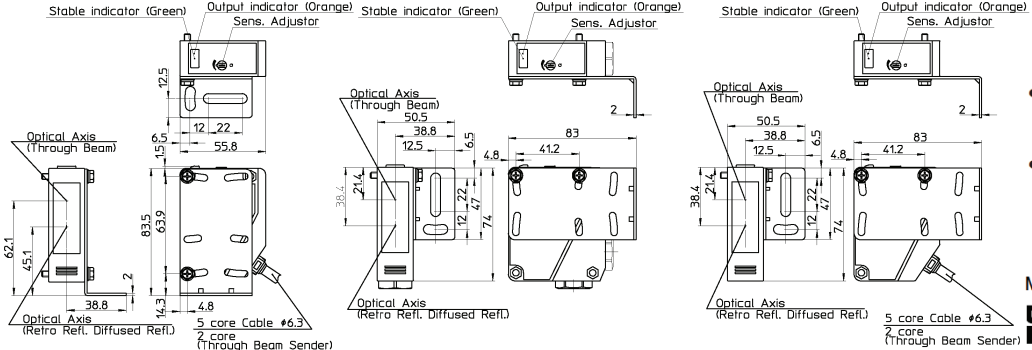

- Specifications and equipment are subject to change without any obligations on the part of manufacture.
- For more information, questions and comments regarding products, please contact us below.

Manufactured and sold by : **OPTEx FA CO., LTD.**